

	Non Hold Open	Hold Open	Sizing
Series No.*	UNI J8300	UNI J8300H	2, 3, 4, 5 or 6
	UNI J8301	UNI J8301H	Multi-Size 1 thru 6
	UNI J8500	UNI J8500H	2, 3, 4, 5 or 6
	UNI J8501	UNI J8501H	Multi-Size 1 thru 6

* These series have a DELAYED ACTION CLOSING option available that is identified with a "DA" suffix to the series number.



The closing force for these series door closers is adjustable from a size 1 to a size 6, as outlined in ANSI Standard A156.4. When these series of door closers are installed and adjusted to conform to ADA reduced opening force requirements (5 lbs max.) for interior doors, they may not have adequate closing force to reliably close and latch the door. Power adjustments charted on Page 4 are recommended where possible, to ensure proper door control.

CAUTION

An incorrectly installed or improperly adjusted door closer can cause property damage or personal injury. These instructions should be followed to avoid the possibility of misapplication or misadjustment.



- Always use template covering door-opening-angle desired, correct door-thickness and frame-reveal, and door-hanging-hardware being used. Template dimensions in these instructions (page 2) cover frame reveals to 7-3/8" (187mm) in opening with 1-3/4" (44mm) thick doors hung on 4-1/2" (114mm) wide template-hinges (figure 2), 3/4" (19mm) offset-pivots (figure 2) or center-pivots (figure 3).
- Check hand of door: right or left (see figure 5, page 3). Make sure that door opens the full angle desired and latches without any binding action or interference. Note that hold-open units will require that door swing five (5) degrees past hold-open point, to dead-stop position.
- It is suggested that sex-nuts and bolts be used to mount arm-foot and to mount closer to flush partitions.
- Top Jamb Unitrols are supplied with arm rod units according to frame-reveal. An arm number is stamped on the arm rods, as shown on Figures 2 and 3 (page 2).

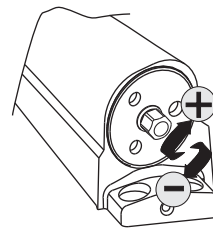

Power Adjust

Use 5/16" Socket or Adjustable Wrench for this Adjustment

Power Adjustment Chart for J8301(H) / J8501(H) ONLY

DOOR	Number of Turns Required			
	MAXIMUM DOOR SIZE			
	32" (0.85M)	36" (0.90M)	42" (1.00M)	48" (1.20M)
Interior Door	4	7	8	9
Exterior Door	7	8	10	12

NOTE: Maximum of 20 turns (360°) of Power Adjustment Shaft. Closer is shipped set at 10 turns.

Components:

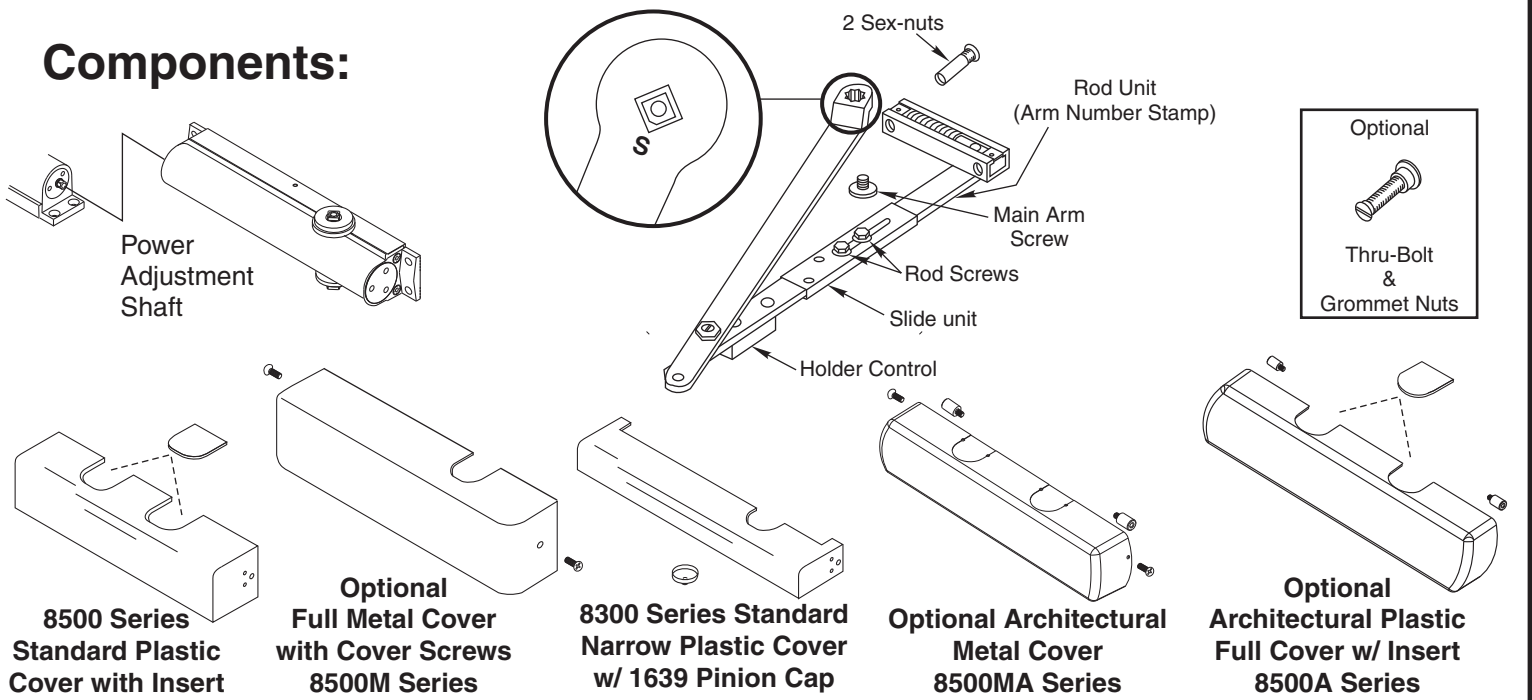

Top-Jamb Installation Template

Figure 1

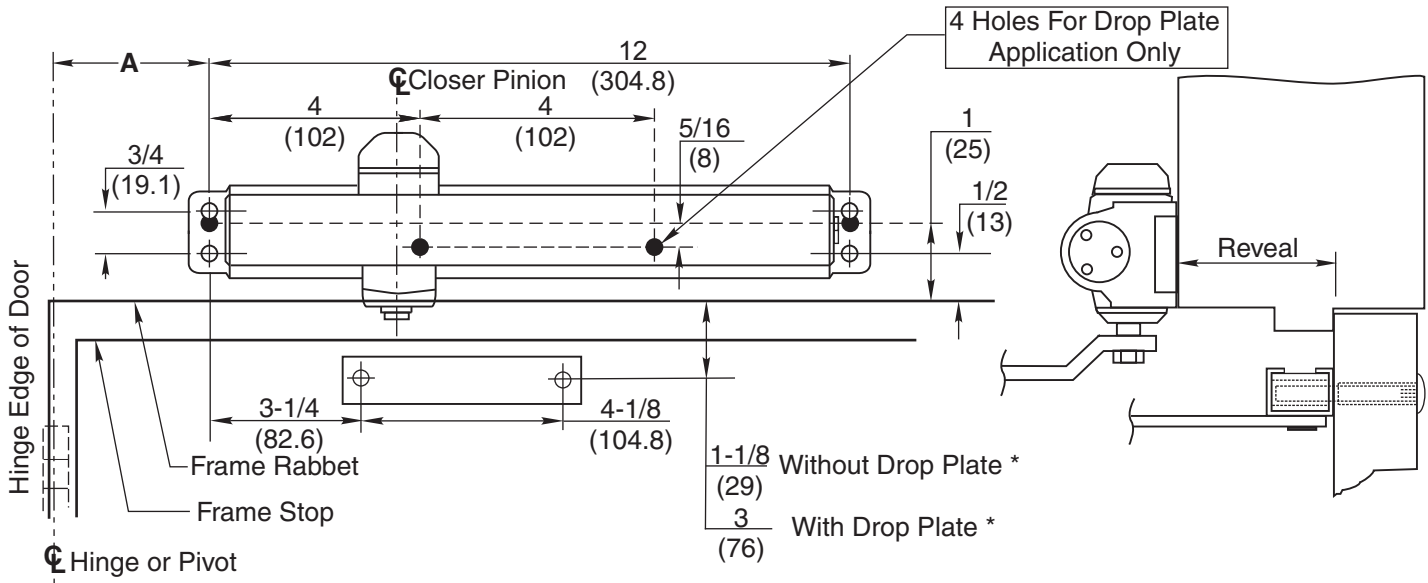

* Always use frame or transom rabbet as reference plane, not bottom of stop.

** For 1-3/4" door with 4-1/2" wide butts or 3/4" offset-pivots, see Figure 2.
For 1-3/4" door with center-pivots, see Figure 3.
All other conditions require special template.

Do Not Scale Drawing

Left Hand Door Shown

Dimensions are in $\frac{\text{inches}}{\text{(mm)}}$

Door-Control location for 1-3/4" (44mm) thick doors hung on 4-1/2" (114mm) wide template-hinges or 3/4" (19mm) offset-pivots. **Figure 2**

Arm Number Stamp	Non-Holder	J6600-4	J6200-4	J6100-4	J6400-4	J6500-41	J6400-42	J6500-43							
	Hold-Open	J6600-7	J6200-7	J6100-7	J6400-7	J6500-71	J6400-72	J6500-73							
Reveal	inches	0 - 3/8	1/2 - 2	2-1/2 - 3-1/4	3-3/8 - 4-1/4	4-3/8 - 5-3/8	5-1/2 - 6-3/8	6-1/2 - 7-3/8							
	mm	0 - 10	13 - 50	55 - 83	85 - 108	111 - 137	140 - 162	165 - 187							
Door Opening Angle		Dimension A		Dimension A		Dimension A		Dimension A							
Hold Open	Door Stop	inches	mm	inches	mm	inches	mm	inches	mm	inches	mm	inches	mm		
85°	90°	9-7/8	251	9-7/8	251	10	254	10	254	10-1/8	257	10-1/4	260	10-1/4	260
90°	95°	9-1/4	235	9-1/4	235	9-3/8	238	9-3/8	238	9-1/2	241	9-5/8	244	9-5/8	244
95°	100°	8-5/8	219	8-5/8	219	8-3/4	222	8-3/4	222	8-7/8	225	9	229	9	229
100°	105°	8-1/8	206	8-1/8	206	8-1/4	210	8-1/4	210	8-3/8	213	8-1/2	216	8-1/2	216
105°	110°	7-5/8	194	7-5/8	194	7-7/8	200	7-7/8	200	8	203	8-1/8	206	8-1/8	206
110°	115°	7-1/4	184	7-1/4	184	7-1/2	191	7-1/2	191	7-3/4	197	7-7/8	200	7-7/8	200

Door-Control location for 1-3/4" (44mm) thick doors hung on center pivots. **Figure 3**

Arm Number Stamp	Non-Holder	J6600-4	J6200-4	J6100-4	J6400-4	J6500-41	J6400-42	J6500-43							
	Hold-Open	J6600-7	J6200-7	J6100-7	J6400-7	J6500-71	J6400-72	J6500-73							
Reveal	inches	0 - 3/8	1/2 - 2	2-1/2 - 3-1/4	3-3/8 - 4-1/4	4-3/8 - 5-3/8	5-1/2 - 6-3/8	6-1/2 - 7-3/8							
	mm	0 - 10	13 - 50	55 - 83	85 - 108	111 - 137	140 - 162	165 - 187							
Door Opening Angle		Dimension A		Dimension A		Dimension A		Dimension A							
Hold Open	Door Stop	inches	mm	inches	mm	inches	mm	inches	mm	inches	mm	inches	mm		
85°	90°	10-1/4	260	10-3/8	264	10-3/8	264	10-1/2	264	10-5/8	270	10-3/4	273	10-3/4	273
90°	95°	9-1/2	241	9-3/4	246	9-3/4	246	9-7/8	251	10	254	10-1/8	257	10-1/8	257
95°	100°	9	229	9-1/8	232	9-1/4	235	9-1/4	235	9-3/8	238	9-1/2	241	9-1/2	241
100°	105°	8-3/8	213	8-1/2	216	8-3/4	222	8-3/4	222	9	229	9-1/8	232	9-1/8	232
105°	110°	8	203	8-1/8	206	8-1/4	210	8-3/8	213	8-5/8	219	8-3/4	222	8-3/4	222
110°	115°	7-1/2	191	7-3/4	197	7-7/8	200	8	203	8-1/4	210	8-3/8	213	8-3/8	213

Installation Sequence

- Set average-power of multi-size closer. (Series UNI J8301, UNI J8501 ONLY) See Power Adjust chart on Page 1.
- See Figure 2 or 3 and select template dimensions. Note: Separate template required for other applications. Figure 2: 1-3/4" (44mm) thick door on 4-1/2" (114mm) wide hinges or 3/4" (19mm) offset-pivots. Figure 3: 1-3/4" (44mm) thick door on center-pivots. Frame reveals and door opening angles as charted; shock absorber will permit five (5) degrees of door travel beyond hold-open position.
- Locate holes on frame face, stop-side. Four (4) for closer (or drop plate).
- Locate holes on door. Two (2) for arm-foot.
- Prepare door and frame for fasteners. See chart "Preparation for Fasteners" (Figure 4). Note: It is recommended to use sex-nuts to fasten arm foot to the door and to fasten the closer body to a flush transom.
- Mount drop plate, (if used) and closer. Closer power adjustment shaft toward lock edge.
- Disassemble rod-unit from arm-assembly and install on door. Rod under shock-absorber and closest possible to lock edge (See Figures 1 and 5).• Mount main arm onto closer pinion shaft, aligning proper arm mark with pinion flat. Secure with main arm screw. Arm Mark "S" (See Figure 5).
- Insert connecting rod into slide unit and preload arm. Secure with rod screws. Adjust rod to perpendicular with door. See Figure 5.
- Adjust closer and install cover. See "Unit Adjustment" on back page.

Preparation for Fasteners			Figure 4
Fasteners	Door or Frame	Drill-Sizes	
Standard	Self-Drilling Screw	Aluminum or Metal	No drill required
		Wood	3/16" (4.30 mm)
	1/4" - 20 machine screw	Metal	Drill: #7 (0.201" dia.) Tap: 1/4" - 20
Optional	Sleeve nuts and bolts	Hollow Metal	9/32" (7 mm) through; 3/8" (9.5 mm) door face opposite to closer
		Aluminum or Wood	3/8" (9.5 mm) through
	Through-bolts and grommet-nuts	All	9/32" (7 mm); 3/8" (9.5 mm) dia. x 3/8" (9.5 mm) deep on door opposite to closer

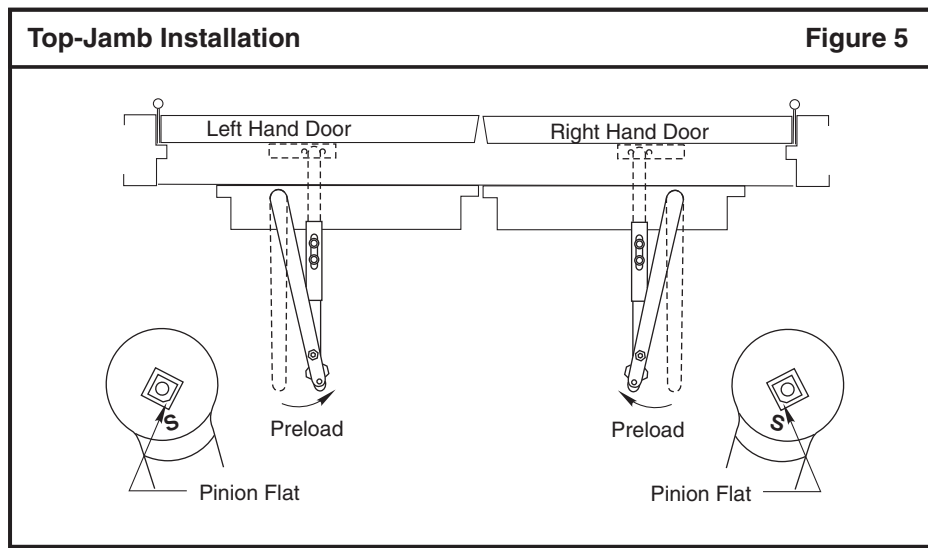

Adjustment Instructions

Closing Power See Figure 6

- Adjust as required.
- **Hold-Open** controls are at arm elbow (models suffixed "H"). To select hold-open on or hold-open off and to adjust the hold open force ... Use screwdriver as illustrated (See Figure 10).

Closing Cycle (hydraulic control) See Figure 7A.

Valve "L" controls door speed in **Latch range**.
 Valve "S" controls door speed in **Sweep range**.
 Valve "D"—Optional—controls door speed in the **Delay range**.
 Use 1/8" hex-key furnished and adjust as shown in Figure 8.

Door closing time should be between 3 and 7 seconds from 90°. Longer closing time may be required for the elderly or handicapped.

Opening Cycle (hydraulic control) See Figure 7B.

Valve "B" cushions (slows) door opening in the **backcheck range**.
 Note: Never close this valve completely or damage to closer may occur.
 Use 1/8" hex-key furnished and adjust as shown in Figure 9.

Installation of Cover:

- **Full cover:** Slide cover insert into the un-used cutout in cover. Install cover using screws provided.
- **Narrow cover:** Install cover using screws provided. Screw pinion cap onto shaft by hand or with a phillips screwdriver - DO NOT OVERTIGHTEN.
- **Full metal cover:** Fasten cover to mounting clips with screws provided.
- **Architectural plastic cover:** Slide cover insert into the un-used cutout in cover. Install standoffs in ends of closer. Snap cover onto standoffs.
- **Architectural metal cover:** Remove cover insert where pinion is located. Install standoffs in ends of closer. Install cover using screws provided.

Closing Power Control Figure 6

Increase

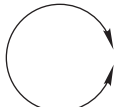

Decrease

For UNI J8301 and UNI J8501 series only, see Power Adjust chart on Page 1.

Power Adjustment Shaft

Use 5/16" Socket or Adjustable Wrench

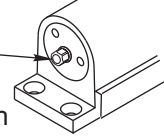

Hydraulic Control

Fig. 7A

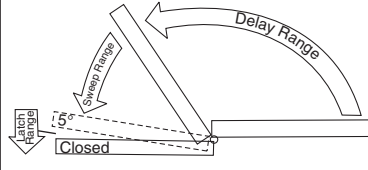

Closing Cycle

Fig. 7B

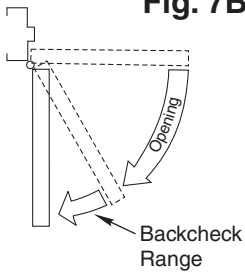

Opening Cycle

Closing Speed Figure 8

Slow

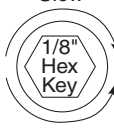

Fast

Latch Valve

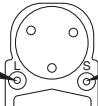

Sweep Valve



Fast

Slow



Fast

Optional Delay Valve

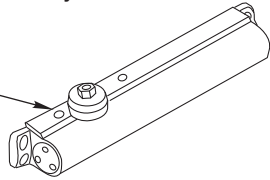

Door Holder Option Figure 10

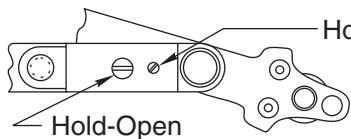

Hold-Open Force

Hold-Open "On"

Turn 90° To "Off"

Press & Turn



To Decrease Force

To Increase Force

Hold-Open option is found at the arm elbow. To select hold-open "on" or hold-open "off" and to adjust the hold-open force ... use screwdriver as illustrated.

Backcheck Figure 9

Increase



Decrease

Backcheck Valve*

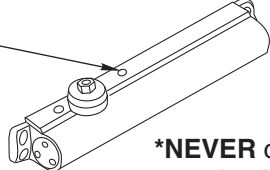

*NEVER close this valve completely.

Norton® is a registered trademark of Yale Security Inc., an ASSA ABLOY Group company. Copyright © 2005, 2008, Yale Security Inc., an ASSA ABLOY Group company. All rights reserved. Reproduction in whole or in part without the express written permission of Yale Security Inc. is prohibited.



ASSA ABLOY

ASSA ABLOY, the global leader in door opening solutions

3000 Highway 74 East • Monroe, NC 28112

Tel: (877)-974-2255 • Fax: (800)-338-0965

www.nortondoortcontrols.com